

Monitoring Relays 3-Phase Load Guard Types DWB01, PWB01

CARLO GAVAZZI

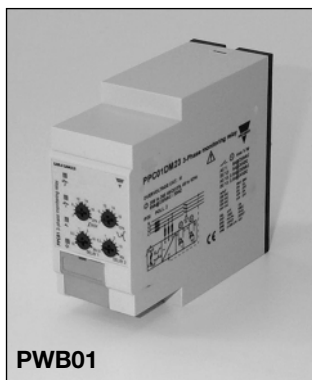

DWB01



PWB01

- TRMS load guard relays for three phase balanced applications
- Measuring if the power factor is within set limits
- Measure voltage on own power supply
- Measuring ranges: 5A, 10A, MI current transformers
- Power ON delay 1 to 30 s knob adjustable
- Separately adjustable upper/lower level on absolute scale
- Programmable latching or inhibit at set level
- Automatic and manual start and stop of the system
- Output: 8 A SPDT relay N.D. or N.E. selectable
- For mounting on DIN-rail in accordance with DIN/EN 50 022 (DWB01) or plug-in module (PWB01)
- 45 mm Euronorm housing (DWB01) or 36 mm plug-in module (PWB01)
- LED indication for relay, alarm and power supply ON

Product Description

DWB01 and PWB01 are precise TRMS power factor monitoring relays for 3-phase balanced systems. They can be used for monitoring the actual load of asynchronous motors and other symmetrical loads, where the power factor is almost proportional to the load.

The relay measures the power factor ($\cos \varphi$), that is the ratio between the active and the apparent power of a motor.

Start/stop input allows to use a manual switch to start and stop the motor, without the need of an auxiliary device.

The advantage of using the latch function is that the relay can be kept energized even after the end of the alarm condition. Inhibit function can be used to avoid relay operation when not desired (maintenance, transients).

The LED's indicate the state of the alarm and the output relay.

Ordering key **DWB 01 C M48 10A**

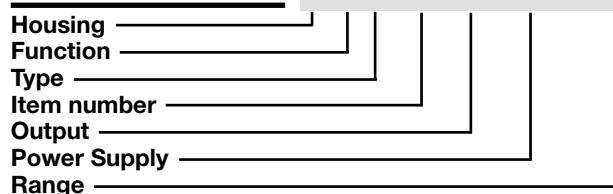

Type Selection

Mounting	Output	Supply: 208 to 240 VAC	Supply: 380 to 480 VAC	Supply: 600 to 690 VAC
DIN-rail	SPDT	DWB 01 C M23 10A	DWB 01 C M48 10A	DWB01 C M69 10A
Plug-in	SPDT	PWB 01 C M23 10A	PWB 01 C M48 10A	

Input Specifications

Input	Measuring ranges	Upper level	Lower level
Voltage (Own power supply):	Power factor ($\cos \varphi$)	0.1 to 0,99	0.1 to 0,99
3 - phase	Direct input:	AACrms	Max. curr. (30 s)
DWB01: L1, L2, L3	Standard CT (examples)	0.5 to 5A	30A
PWB01: 5, 6, 7	TADK2 50 A/5 A	1 to 10A	50A
M23: 208 to 240 VAC \pm 15%	TAD2 150 A/5 A		
DWB01CM48: 380 to 480 VAC \pm 15%	TAD6 400 A/5 A		
PWB01CM48: 380 to 415 VAC \pm 15%	TAD12 1000 A/5 A		
DWB01CM69: 600 to 690 VAC \pm 15%	TACO200 6000 A/5 A		
1- phase	MI CT ranges		
DWB01CM23: L1, L2 (connect pins L2, L3)	MI 100		
PWB01CM23: 5, 6 (connect pins 6, 7)	MI 500		
208 to 240 VAC \pm 15%			
Current:			
DWB01: 5A, 10A: I1, I2			
MI...: U1, U2			
PWB01: 5A, 10A: 11, 10			
MI...: 9, 8			

Input Specifications (cont.)

Note: The input voltage cannot raise over 300 VAC with respect to ground (PWB01 only)	
Contact input DWB01 PWB01 Disabled Enabled Pulse width	Terminals Z1, U1 Terminals 2, 9 > 10 k Ω < 500 Ω > 500 ms
Hysteresis	PF approx 0.1

General Specifications

Power ON delay	1 to 30 s \pm 0.5 s
Reaction time	(input signal variation from -20% to +20% or from +20% to -20% of set value)
Alarm ON delay	< 200 ms
Alarm OFF delay	< 200 ms
Accuracy Temperature drift Delay ON alarm Repeatability	(15 min warm-up time) \pm 1000 ppm/ $^{\circ}$ C \pm 10% on set value \pm 50 ms \pm 0.5% on full-scale
Indication for Power supply ON Alarm ON	LED, green LED, red (flashing 2 Hz during delay time)
Output relay ON	LED, yellow
Environment Degree of protection Pollution degree Operating temperature @ Max. voltage, 50 Hz @ Max. voltage, 60 Hz Storage temperature	IP 20 3 (DWB01), 2 (PWB01) -20 to 60 $^{\circ}$ C, R.H. < 95% -20 to 50 $^{\circ}$ C, R.H. < 95% -30 to 80 $^{\circ}$ C, R.H. < 95%
Housing dimensions DIN-rail version Plug-in version	45 x 80 x 99.5 mm 36 x 80 x 87 mm
Weight	Approx. 250 g
Screw terminals Tightening torque	Max. 0.5 Nm acc. to IEC 60947
CE-Marking	Yes
EMC Immunity Emissions	Electromagnetic Compatibility According to EN 61000-6-2 According to EN 50081-1

Output Specifications

Output	SPDT relay
Rated insulation voltage	250 VAC
Contact ratings (AgSnO₂)	μ
Resistive loads	AC 1 8 A @ 250 VAC DC 12 5 A @ 24 VDC
Small inductive loads	AC 15 2.5 A @ 250 VAC DC 13 2.5 A @ 24 VDC
Mechanical life	\geq 30 x 10 ⁶ operations
Electrical life	\geq 10 ⁵ operations (at 8 A, 250 V, cos ϕ = 1)
Operating frequency	\leq 7200 operations/h
Dielectric strength Dielectric voltage Rated impulse withstand volt.	According to EN 60947-1 \geq 2 kVAC (RMS) 4 kV (1.2/50 μ s)

Supply Specifications

Power supply Rated operational voltage Through terminals:	Overvoltage cat. III (IEC 60664, IEC 60038)
DWB01:	L1, L2, L3
PWB01:	5, 6, 7
M23	177 to 276 VAC 45 to 65 Hz
DWB01CM48	323 to 552 VAC 45 to 65 Hz
PWB01CM48	323 to 477 VAC 45 to 65 Hz
DWB01CM69	510 to 793 VAC 45 to 65 Hz
Dielectric voltage	None
Dielectric voltage supply to output	4 kV
Rated operational power	
M23:	9 VA @ 230 VAC, 50 Hz
M48:	13 VA @ 400 VAC, 50 Hz
M69:	21 VA @ 600 VAC, 50 Hz
Supplied by	L1 and L2

Mode of Operation

DWB01 and PWB01 can be used for monitoring the actual load (no matter if capacitive or inductive) of asynchronous motors. The relay measures the absolute value for the power factor of the system PF= Active Power/Apparent Power that is for balanced system with sinus waveforms the cosine of the angle between motor current and motor voltage (cos ϕ). As cos ϕ varies with the load of the motor, underload and overload can be indirectly detected by DWB01 and PWB01.

The relation between the load and cos ϕ depends on the type of motor. As a guideline to ensure correct working conditions for a motor, the upper level could be set above the cos ϕ marking on the motor, and the lower level under this value. It is anyway recommended to make the adjustment in connection with a practical test. The relay has an adjustable power ON delay in order to avoid overload detection during motor start.

Mode of Operation (cont.)

Example 1

Latching mode, relay NE

In this application DWB01 or PWB01 are connected to an external current metering transformer, type MI..., (connected between Y1 & Y3) as well as to a 3-phase asynchronous motor. The relay energizes as soon as the power supply is applied. After the power ON delay, the unit starts measuring $\cos \varphi$. If $\cos \varphi$ is within the setpoints the relay is energized. As soon as the power factor drops below the lower setpoint or exceeds the upper setpoint the output relay releases and the red LED turns on after the set time has expired. To restart the $\cos \varphi$ measurement, connect Z1 and U1 (2 and 9) or interrupt the power supply for at least 1 s.

Example 2

Non-latching mode, relay NE

DWB01 and PWB01 react as described in the previous example 1 except for the automatic reactivation of the relay as soon as $\cos \varphi$ is back within the two setpoints. When the measured $\cos \varphi$ exceeds the adjusted upper level, the red LED starts flashing. The output relay releases after the set time period. When the measured $\cos \varphi$ drops below the adjusted lower level, the red LED starts flashing, and the output relay releases after the set time period. When the output relay releases there will be no LED indication.

Example 3

1-Phase load monitoring

DWB01CM2310A and PWB01CM2310A can be used for monitoring the power factor of a 1-Phase load with 208 to 240 V AC mains voltage. In this case the power supply has to be connected between L1, L2 (or 5, 6), L2 and L3 (or 6 and 7) have to be connected.

Example 4

Start/stop mode, relay NE

In this application DWB01 or PWB01 are directly connected to a 3-phase asynchronous motor. The relay energizes as soon as the power supply is applied and the start/stop contact is closed. After the power ON delay, the unit starts mea-

suring $\cos \varphi$. If $\cos \varphi$ is within the setpoints the relay energizes. As soon as the power factor drops below the lower setpoint or exceeds the upper setpoint the output relay releases and the red LED turns ON after the set time has expired. When the start/stop contact is opened the relay de-energizes immediately. To restart the system just connect the start/stop contact.

Note: in case of current below the minimum level the alarm is conventionally OFF.

Function/Range/Level/Time Setting

Select the desired function setting the DIP-switches 1 to 4 as shown on the left. To access the DIP-switches open the plastic cover using a screwdriver as shown on the right.

If DIP switch 2 is set to ON (latch/inhibit) the position of DIP-switch 4 does not affect the products working mode.

Centre knobs:
Setting of upper and lower level of $\cos \varphi$ 0.1 to 0,99.

Lower left knob:
Setting of delay on absolute scale: 0.1 to 30 s.

Lower right knob:
Setting of power ON delay on absolute scale: 1 to 30 s.

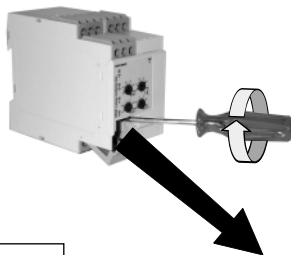

Contact input working mode		
	closed	open
Latch	not active	active
Inhibit	active	not active
Start/stop	start	stop

Input current range (terminals I1, I2 or 10, 11)
ON: 10A
OFF: 5A/MI input

Relay status
ON: Relay de-energized in normal condition
OFF: Relay energized in normal condition

Working mode
ON: Contact input for start/stop functions
OFF: Contact input for latch/inhibit functions

Contact input (SW4 does not affect the working mode if SW3 is ON)
ON: Latch function enable
OFF: Inhibit function enable



Wiring Diagrams

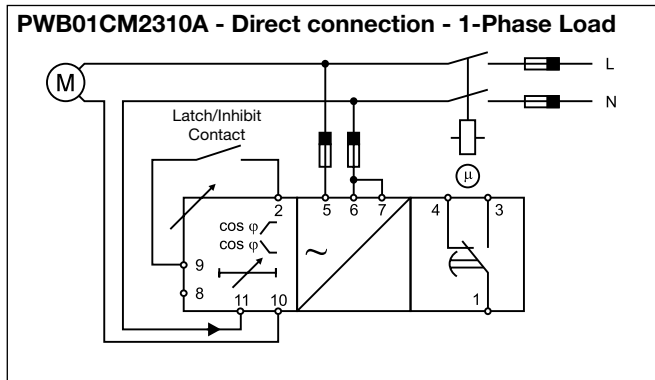
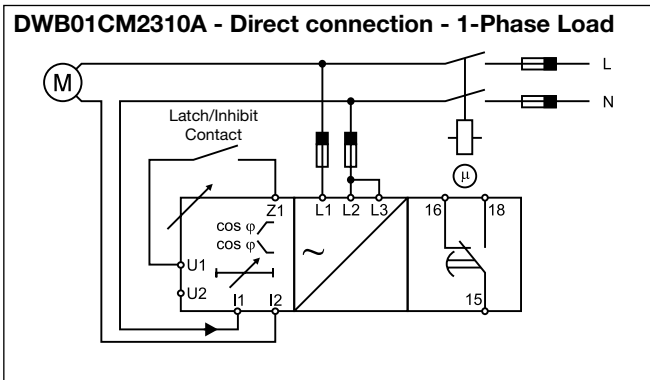
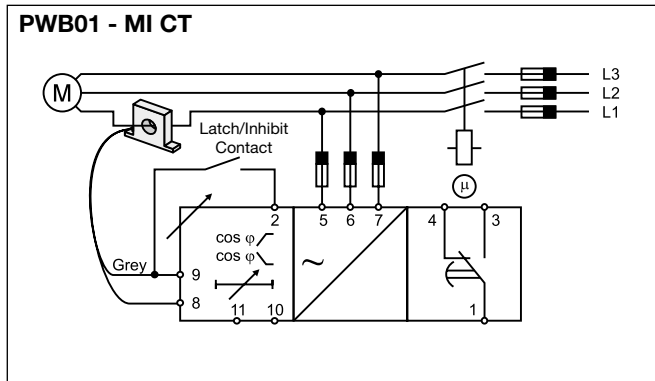
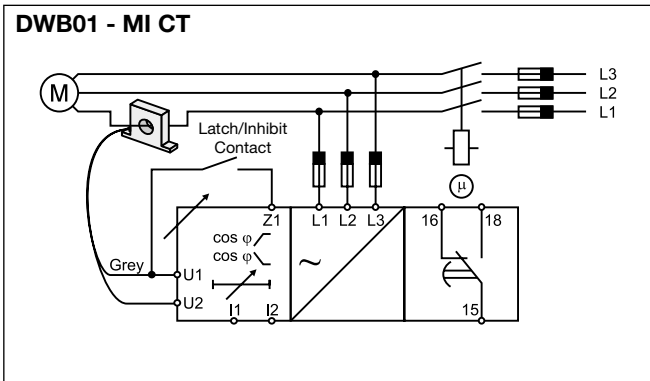
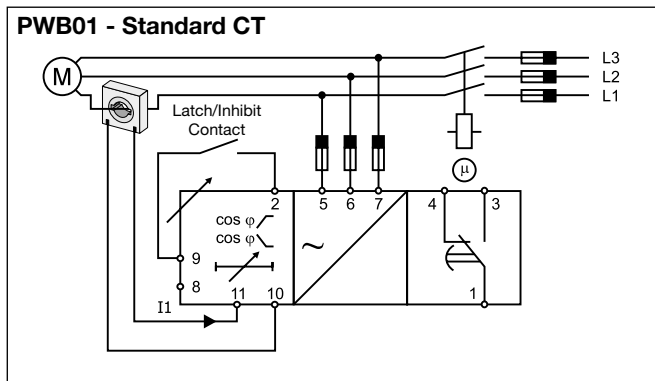
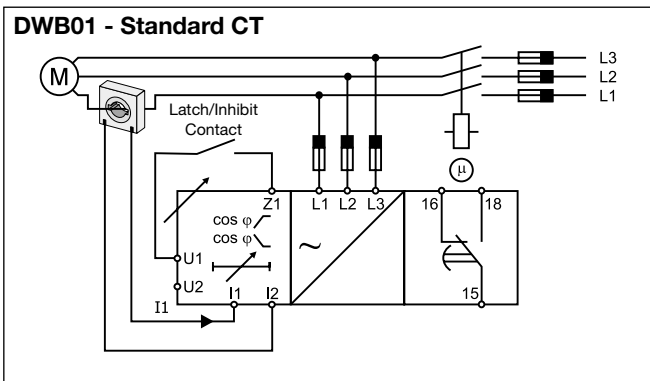
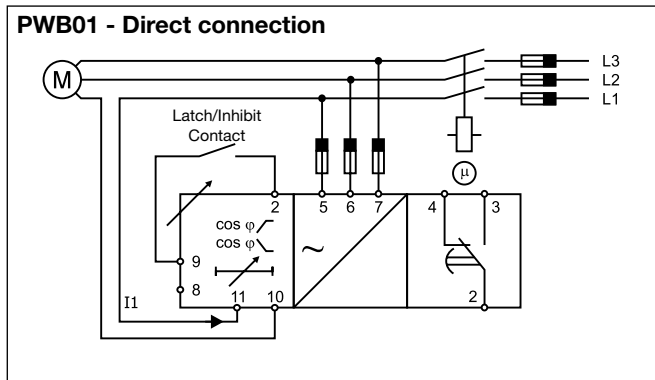
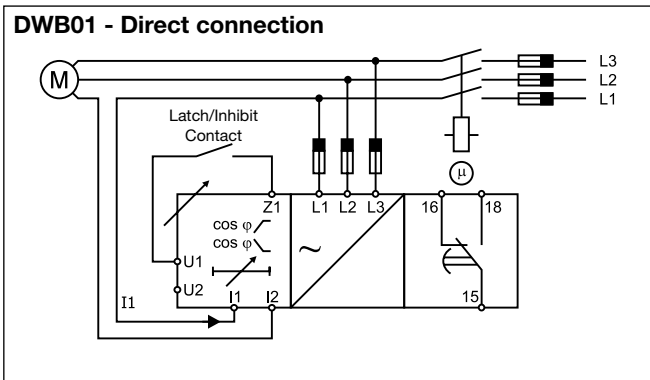

Wiring Diagrams (cont.)

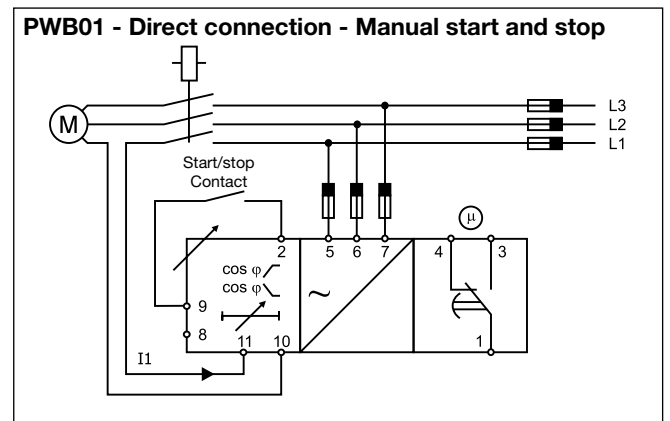
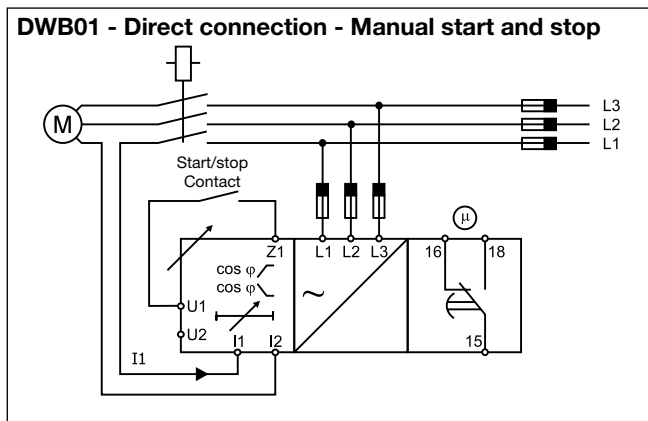

Operation Diagrams

Latch function - NE relay

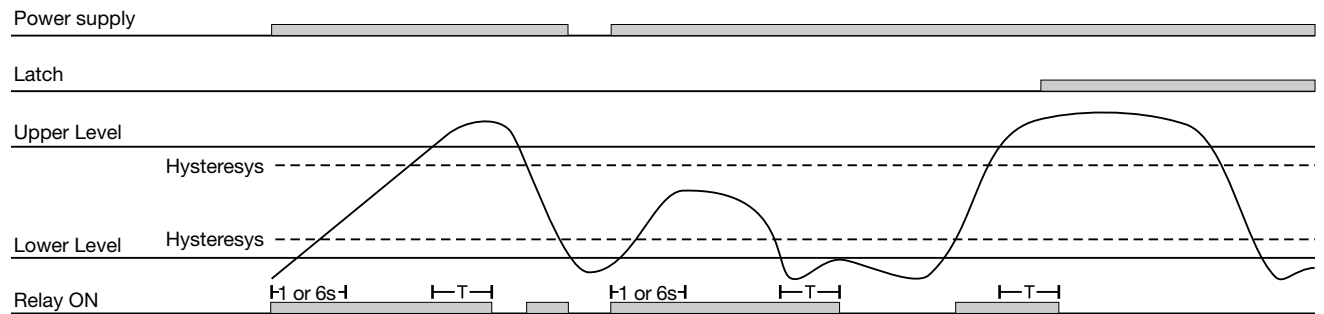

Inhibit function - ND relay

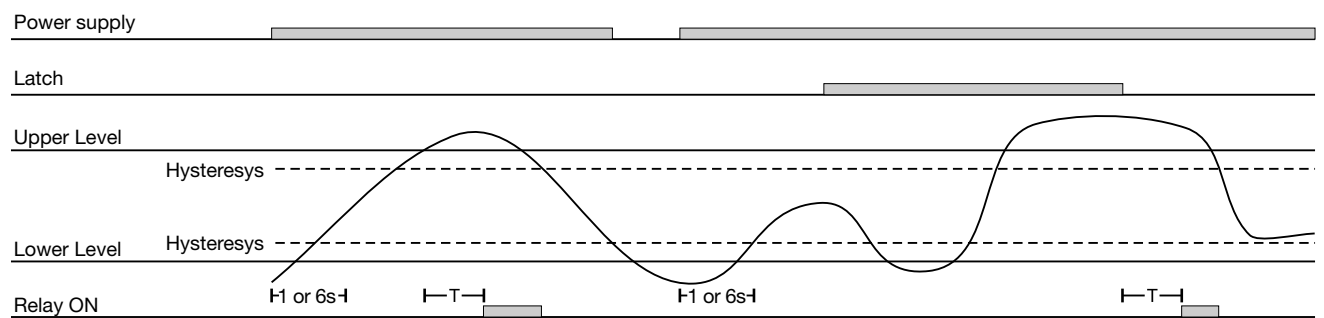

Start and stop function - NE relay

